

## STM Humus Super M42 (105) Deck

Pedestrian

Version 2 - April 2009

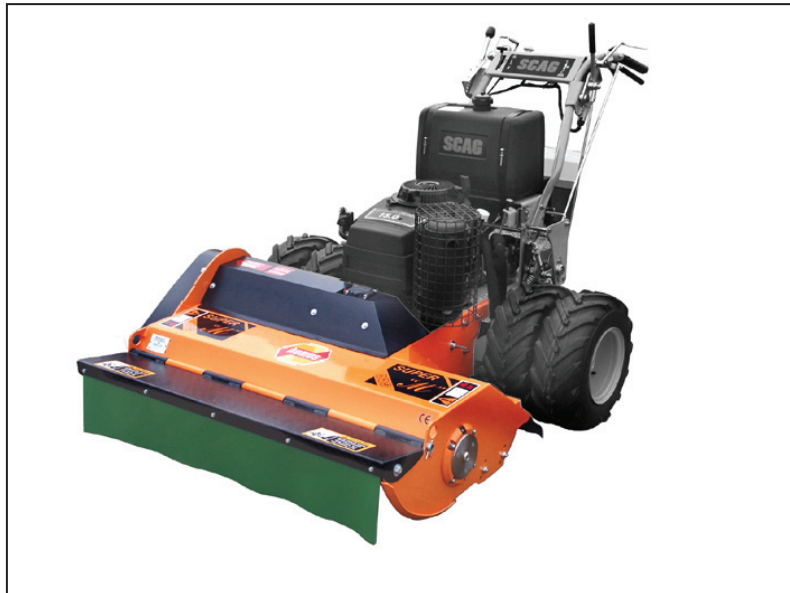

**Simon Tullett Machinery Company Limited**

Tel: 01789 488450 • Fax: 01789 488032 • Email: [sales@st-mach.com](mailto:sales@st-mach.com) • [www.st-mach.com](http://www.st-mach.com)

## STM Humus Super M42 deck

### **BELT ADJUSTMENTS**

To adjust the engine-driven belt, remove the guard (43)

#### Engine-driven belt

Tighten nut to keep washer level with face of endplate [see figure 2]

**Do not over-tension!**

#### Twin rotor drive belts

Remove guard (19), slacken locknut (34) in centre of flat pulley (35), and adjust by use of jack-screw. Re-tighten locknut. (See illustration below).

**Do not over-tension belts!**

fig. 1

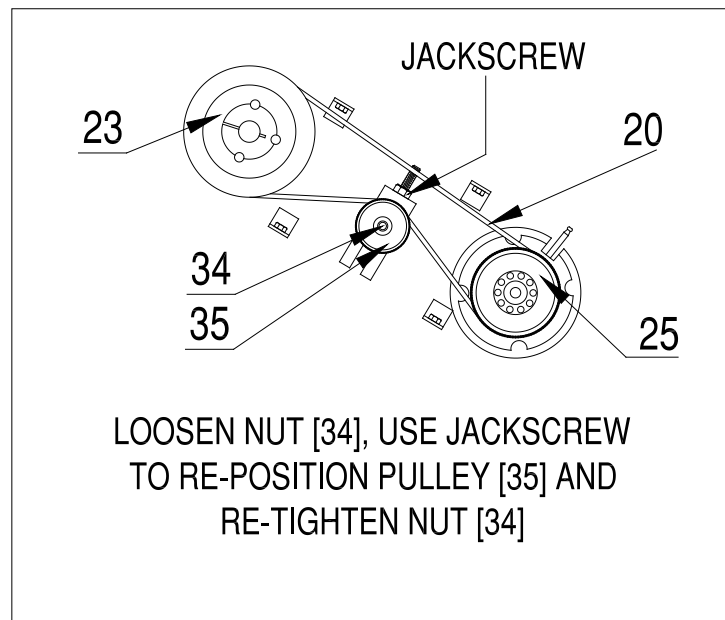

### **BELT REPLACEMENT**

#### Engine-driven belt

Remove guard (43): Undo and remove nut and spring shown in fig 2. This slackens off the electric clutch pre-tension mechanism.

Replace belt.

Re-assemble belt tensioner and finally tighten the nut until the washer is level with the face of the endplate. [See illustration]

## STM Humus Super M42 deck

### **BELT REPLACEMENT [continued]**

*fig 2*

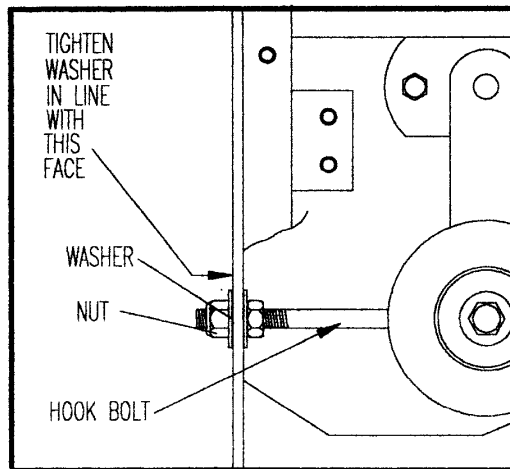

*Illustration for pre-tensioning pulley*

#### Rotor belts

Remove guard (27), slacken adjuster pulley (35) to bottom of slide and remove belts.

**ALWAYS REPLACE THESE BELTS IN PAIRS.**

Adjust belt tension as above and refit guard.

### **LUBRICATION & MAINTENANCE**

#### Gearbox

Check level every 100 hours and top up as required.

Remove level plug and fill through plug hole with gear oil EP80/140.

#### Duplex chain (22)- gearbox to top pulley

Lubricate with Open Chain Oil – daily

#### Bearings

Driveshaft (27) - give 2 or 3 shots with a hand-held grease gun every 500 hours. **DO NOT OVER-GREASE**

Rotor shaft – 2 or 3 grease shots **every 20 hours**. Grease nipples accessed at each end.

**Both ends must be greased. This procedure is vital to the working of the unit.**

#### Roller

Grease bearings [each end] with 2-3 shots, daily.

Caster wheels: (swivel and axle nipples) - lubricate every 12-14 hours.

## STM Humus Super M42 deck

### VISUAL CHECKS

#### Belt tension:

*Check after initial ten hours and adjust as necessary. After that, check and adjust every 10 hours.*

#### Flaps:

*Check for damage, cracks or wear and replace as necessary*

#### Bolts / Nuts:

*Check none have loosened [after initial ten hours, then weekly]*

#### Cutters:

*Check condition of cutting teeth units daily and replace if damaged.*

#### Caster wheels:

*Should be free to swivel and revolve freely. Check for damage to tyres and replace if required.*

### **NOTE**

*If machine supplied with optional casters,  
the spreader bar [part 67 on the exploded diagram]  
**MUST BE INSTALLED** for non-roller cutting requirements  
to prevent risk of damage to rotor bearings*

*Utilise the rotor fixings.*

# STM HUMUS 42 Sheet 1

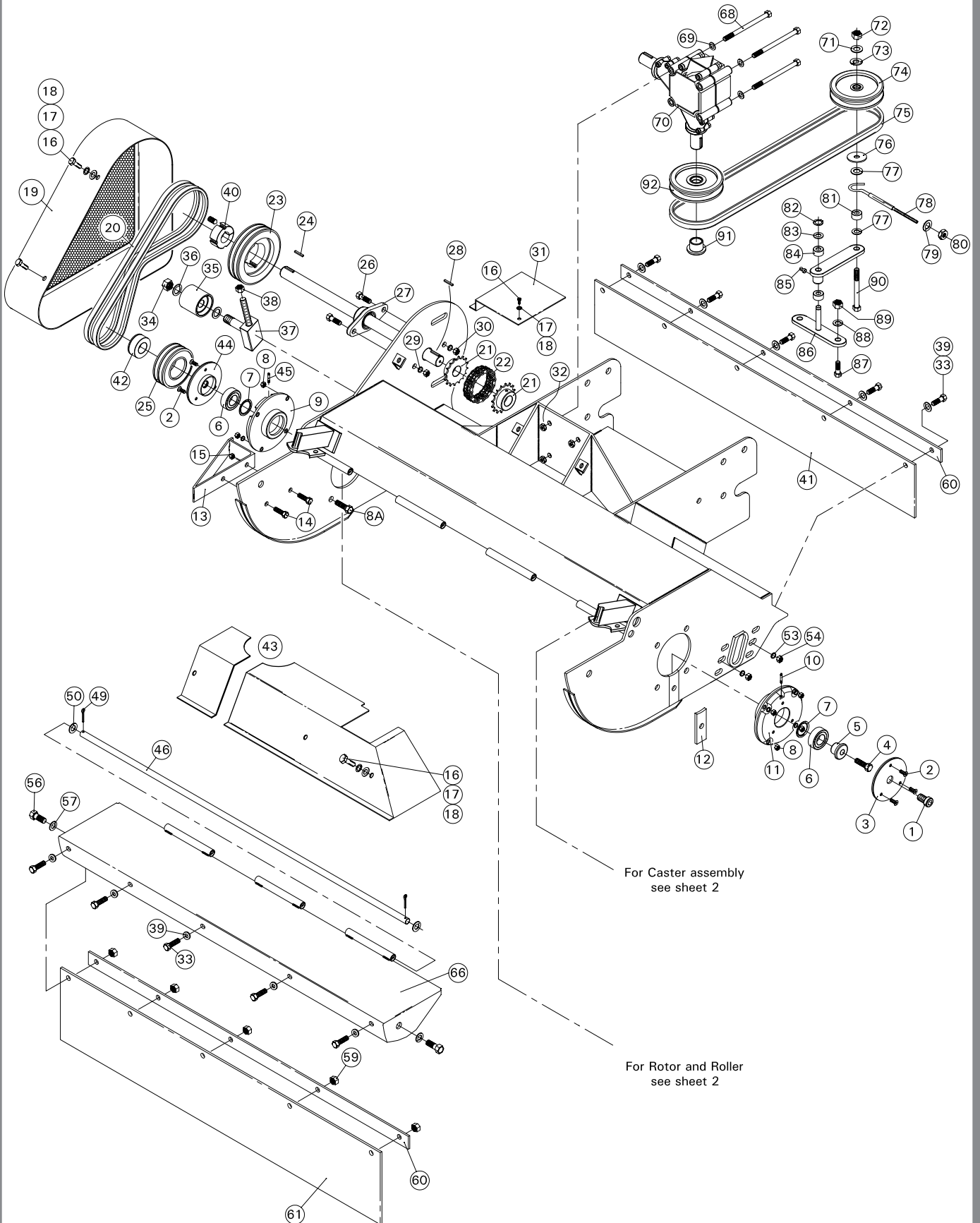

# STM HUMUS 42 Sheet 2

## Roller - Roller

### Optional caster assembly and spreader bar

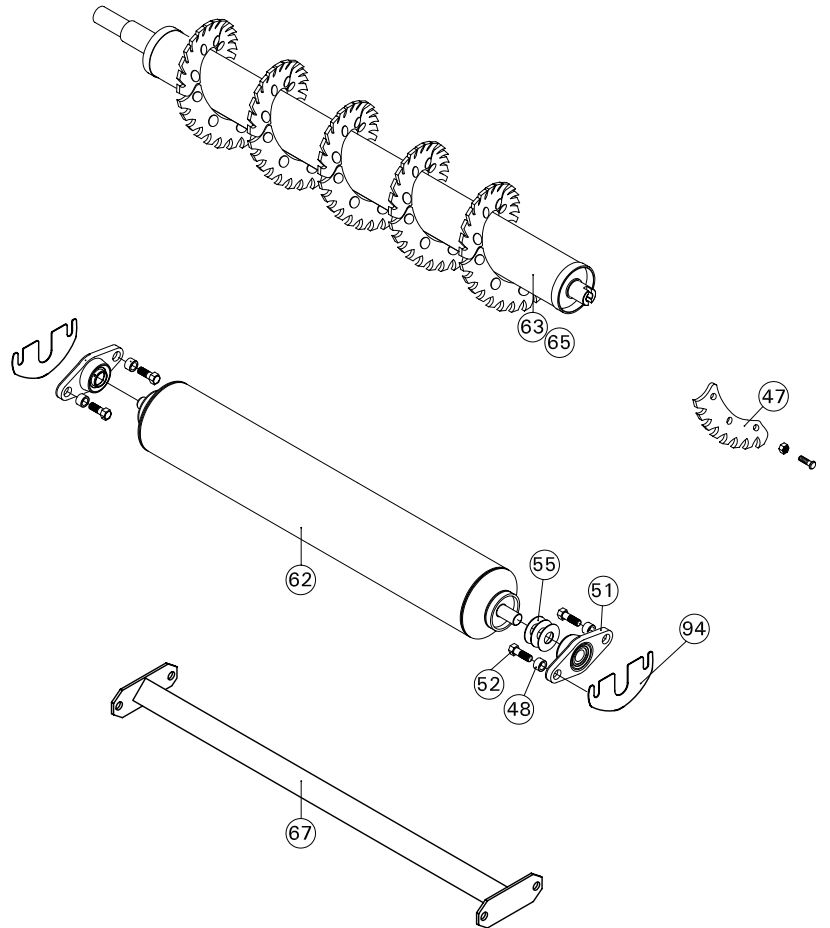
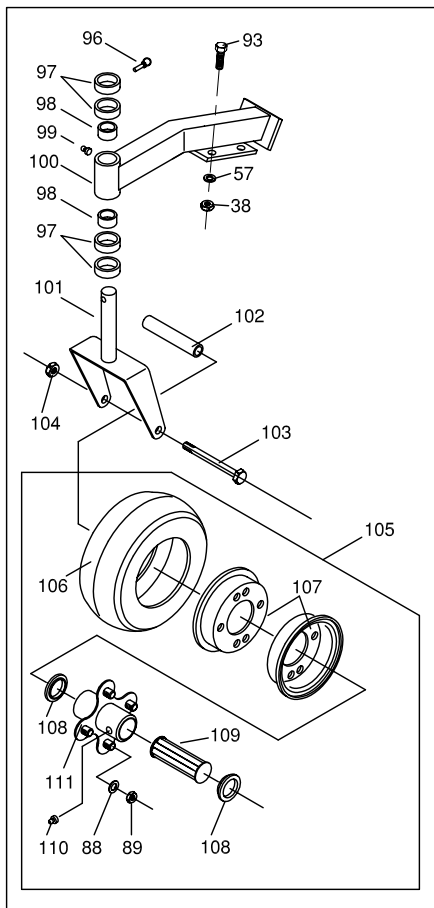

### STM Humus Super M42 deck

Drawing ref	Part No.	Description
1	M26391634	Pipe plug
2	M97991015	Flathead screw
3	M26391616	Cover
4	M90912152	Allen Bolt
5	M90127003	Retainer
6	M89022207	Bearing
7	M83002007	Seal
8	M81000335	Nut
8A	M97991605	Bolt
9	M26395184	Bearing casing
10	M97141201	Grease nipple [short]
11	M26395185	Bearing casing
12	10462	Filler plate
13	10463	Deflector
14	PL	Bolt
15	PL	Nut
16	PL	M6 x 15 Bolt
17	PL	M6 Spring washer
18	PL	M6 Flat washer
19	10493	Rotor end guard
20	10494	Belts [set of 2]
21	10453A	Coupling assembly: incl. 22
22	10453A	Coupling assembly: chain only
23	10495	Pulley set
24	10468A	Key 8 x 7 x 35
25	M26619538	Pulley
26	PL	M8 x 35
27	10003	Bearing
28	10468A	Key 8 x 7 x 30
29	PL	M8 Spring washer
30	PL	Nut: M8 Nyloc
31	10496	Guard
32	PL	Nut: M10 Nyloc
33	PL	Nut: M12 Nyloc
34	PL	Nut: M12 Nyloc
35	10009	Tensioner roller
36	10469	Flat washer
37	10470	Adjuster block
38	PL	Nut: M10 Nyloc
39	PL	M6 Flat washer

### STM Humus Super M42 deck

Drawing ref	Part No.	Description
40	10471	Taper bush
41	M26891522	Rear flap
42	M80013002	Keyless bush
43	10497	Guard - two pieces
44	M26691537	Bearing cover
45	M97141201	Grease nipple [long]
46	M26891414	Shaft
47	M26695108	Full blade set: 15 [blade & fixings]
48	M81400422	Spacer [bearing]
49	PL	Cotter pin
50	PL	Flat washer
51	M89000025	Bearing
52	M90927004	Bolt
53	M90127004	Washer
54	M90934005	Nut
55	M26891361	Spacer
56	PL	Bolt: M10 x 25
57	PL	M10 flat washer
58	PL	Nut: M10 Nyloc
59	PL	Nut: M6 Nyloc
60	M26891507	Retaining strip
61	M26891520	Front flap
62	M26895061	Roller
63	M27095102	Shaft complete
64	10498	Hood - cowling only
65	10580	Shaft
66	M26895231	Front guard
67	10597	Spreader bar
68	PL	Bolt
69	PL	Washer: 24 x 10 x 3
70	10013	Gearbox
71	10019-B	Pulley
72	PL	Hex nut: 3/8"
73	PL	Spring washer 3/8"
74	10239	Pulley assy inc. brg. and bush
75	10353	Belt
76	43063	Spacer
77	PL	Washer 10 x 21
78	44101	Eye bolt
79	PL	Washer 24 x 10 x 3



### STM Humus Super M42 deck

Drawing ref	Part No.	Description
80	PL	Nut: M10 Nyloc
81	PL	Washer 3/8 x 2"
82	04050-02	Retainer ring
83	PL	Flat washer
84	48100-05	Bronze brg.
85	43114-01	Grease nipple
86	45037	Idler pivot
87	PL	Bolt: M8 x 30
88	PL	Spring washer - 8mm
89	PL	Hex nut - 8mm
90	PL	Bolt: 3/8 x 3"
91	10045	Taper hub lock
92	482646	Pulley
93	PL	Bolt: M10 x 35
94	M26691397	Spacer
95		
96	04066-01	Quick pin
97	43037-01	1/2" Spacer [caster yoke]
98	48100-01	Bronze bearing
99	48114-04	Grease nipple
100	10547	Support arm
101	45006	Caster yoke
102	43022	Sleeve [caster wheel bearing]
103	04001-37	Bolt
104	04021-07	Hex locknut: 1/2" x 13
105	48307	Wheel assy: [inc 88, 89 & 106-111]
106	481774	Tyre only [caster wheel]
107	481772	Rim only [caster wheel]
108	481770	Bearing retainer [caster wheel]
109	481769	Roller bearing [caster wheel]
110	48114-03	Grease nipple
111	481768	Hub assy - incl. bolts
112	481773	Inner tube only [caster wheel]

PL \_ Purchase Locally